



Superior Magnetics Since 1979



## CMLI-15/15B

**Line Input Transformer**  
**1 : 1 Winding Ratio - Dual Shields Optional**

- Use to balance unbalanced inputs
- High input impedance: 18kΩ with 15K load
- Good bandwidth (-3 dB at 72 kHz - 15K load)
- Excellent CMRR: Single shield - 105 dB at 60 Hz
- Dual shield - 110 dB at 60 Hz
- Maximum input level +20 dBu at 20 Hz

The CineMag CMLI-15/15B is commonly employed with wideband input amplifiers. It exhibits good bandwidth, common mode rejection ratio (CMRR), and distortion characteristics. It is available with either single or dual shields. It is designed to operate well when driven by 600Ω lines. All the wires connecting the internal foil shields between windings are spot welded for maximum long term reliability, as is done with all CineMag transformers. It is encased in a μMetal can which provides 30 dB of magnetic shielding. It is available either with p.c. mount, or leaded versions can be mounted with threaded bushing, studs, or screw holes.

**CMLI-15/15B[PC] <Single Shield> - CMLI-15/15B2[PC] <Dual Shields>**

Parameter	Conditions	Typ
Turns Ratio		1 : 1.00
Input impedance, Zi	1 kHz, +4 dBu RL=15k Test Circuit 1	18.0 kΩ
	1 kHz, +4 dBu RL=10k Test Circuit 1	13.0 kΩ
Voltage Gain	1 kHz, +4 dBu Test Circuit 1 Rs=600Ω RL=15 kΩ	-2.2 dB
Distortion (THD+N%)	1 kHz, +4 dBu Test Circuit 1 Rs=600 RL=15K	0.0007%
	20 Hz, +4 dBu Test Circuit 1 Rs=600 RL=15K	0.02%
Max 20 Hz input level	1.0% THD; Rs=600Ω RL=15KΩ Test Circuit 1	+20 dBu
Response, ref 1 kHz	20 Hz +4 dBu Rs=600Ω RL=15KΩ Test Circuit 1	-0.03 dB
	20 kHz +4 dBu Rs=600Ω RL=15KΩ Test Circuit 1	-0.1 dB
Phase Shift at 20Hz	Referenced to source generator Test Circuit 1	+1°
Phase Shift at 20 kHz		-18°
CMRR Single Shield	60 Hz Test Circuit 2 per IEEE Std 389-1996 ¶19 RL=15KΩ	103 dB
	1 kHz Test Circuit 2 per IEEE Std 389-1996 ¶19 RL=15KΩ	76 dB
CMRR Dual Shield	60 Hz Test Circuit 2 per IEEE Std 389-1996 ¶19 RL=15KΩ	110 dB
	1 kHz Test Circuit 2 per IEEE Std 389-1996 ¶19 RL=15KΩ	87 dB
Operating Temp Range	Operation and storage	0° C Min 70° C Max
Max Soldering Temp (p.c.)	5 Seconds	335° C Max

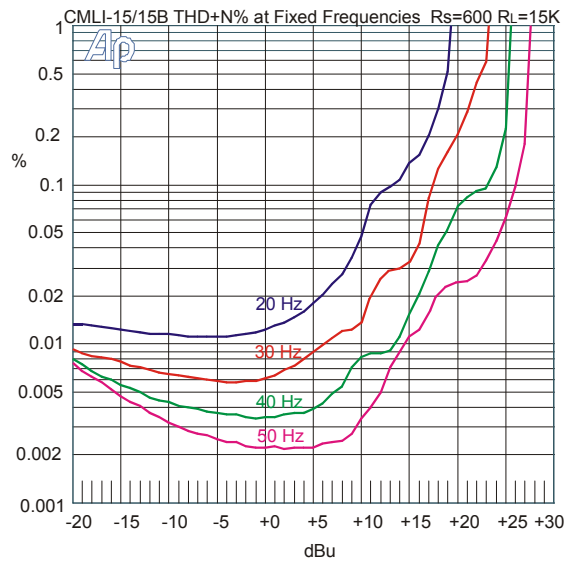
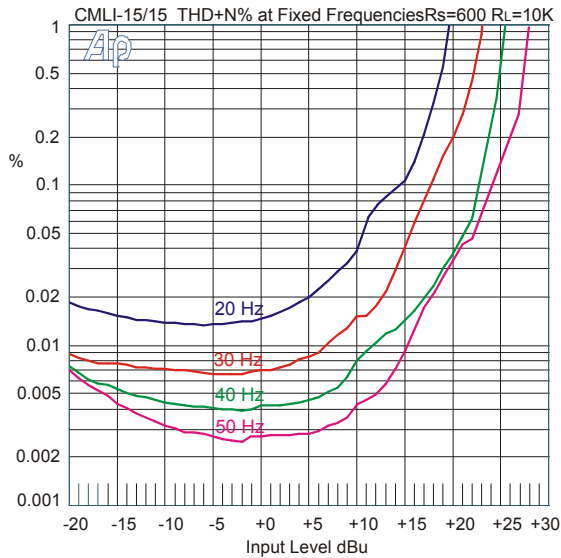
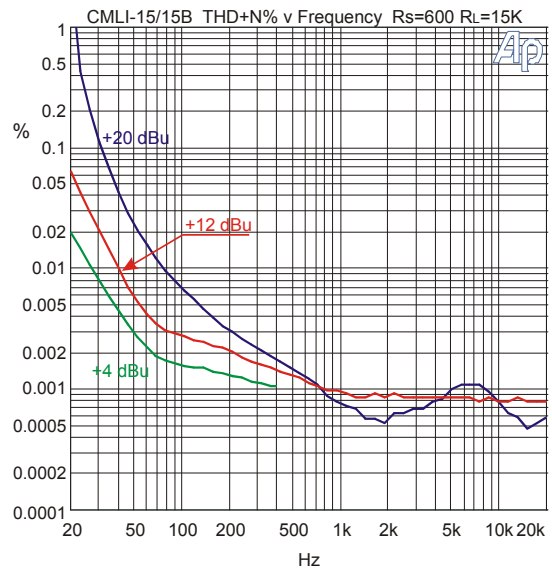
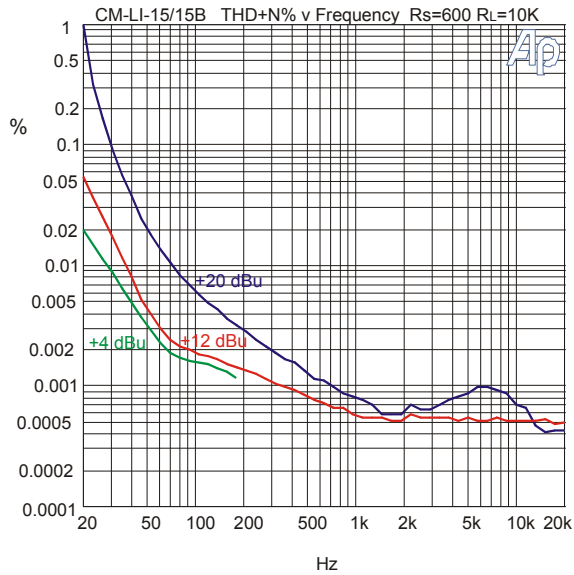
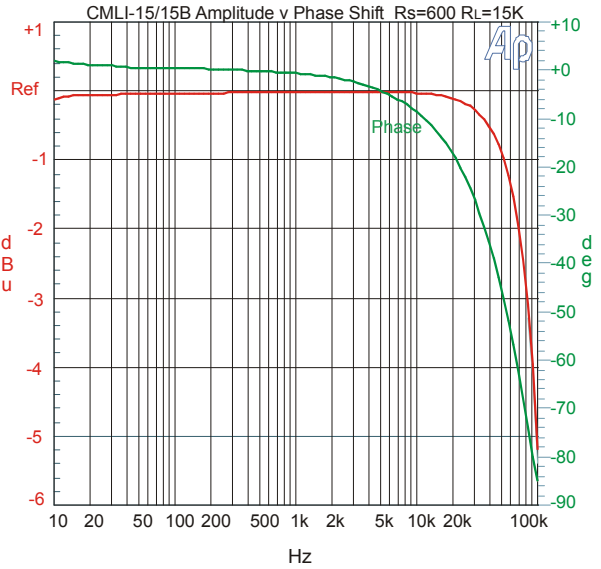
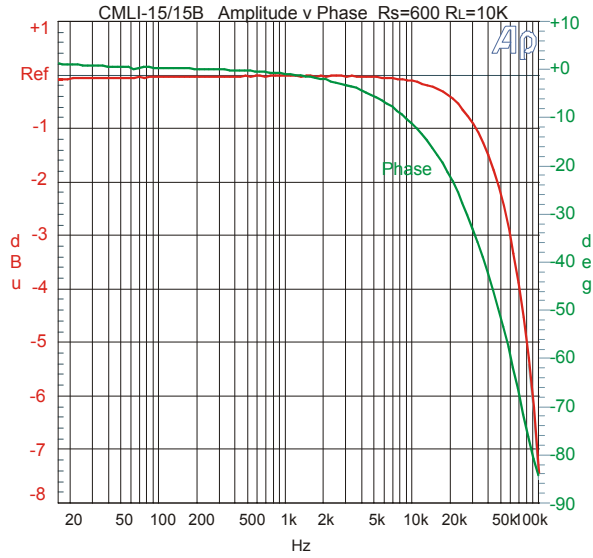

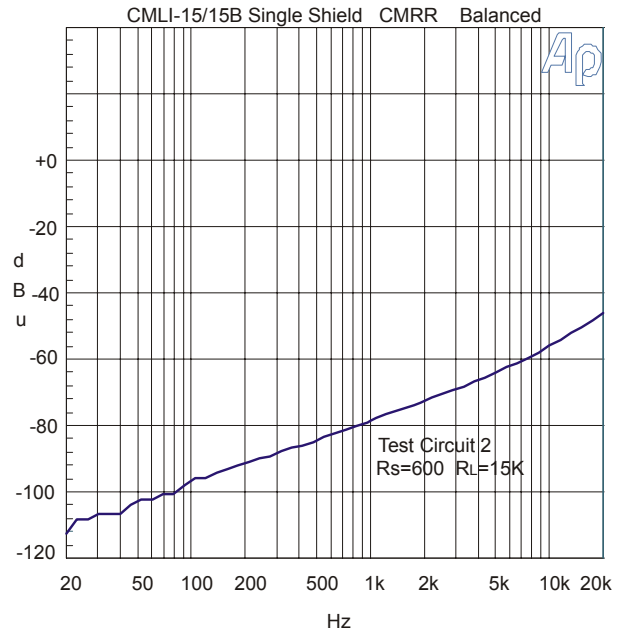
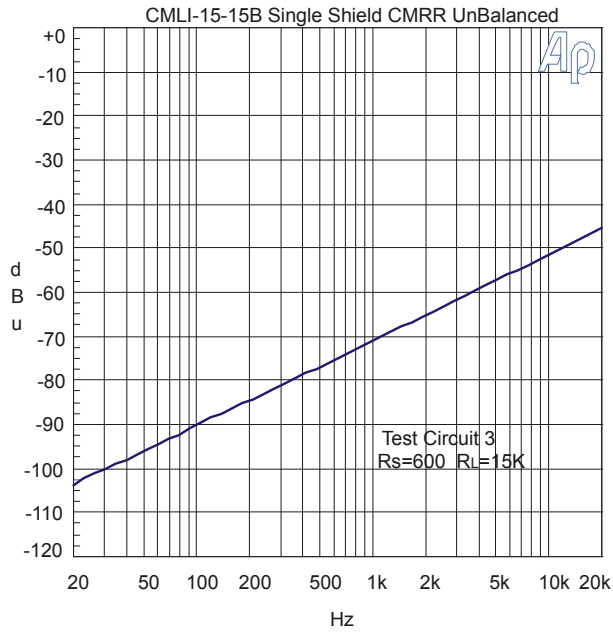
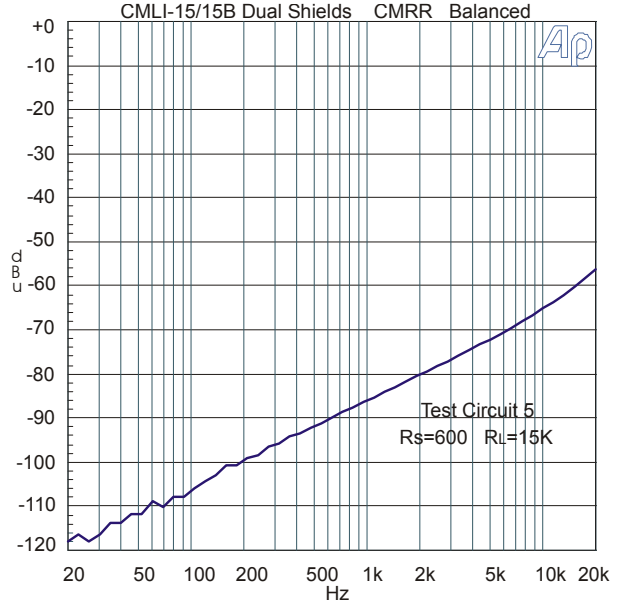
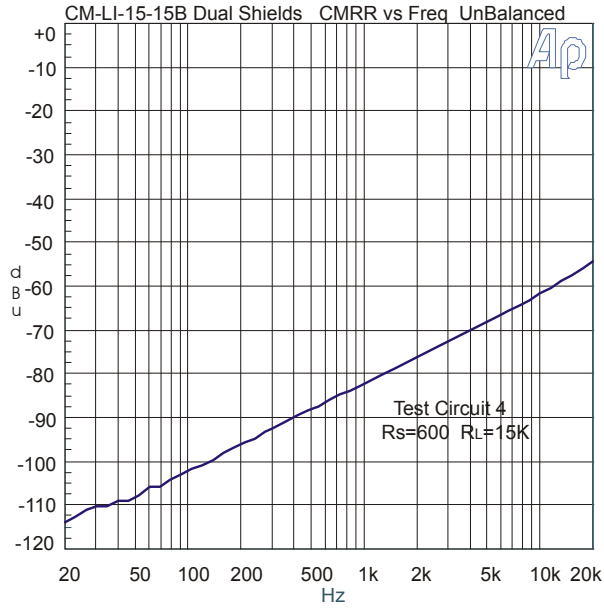

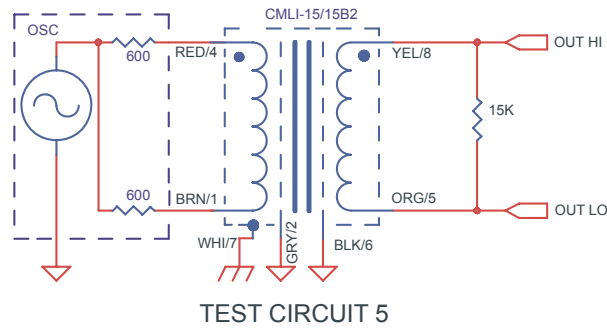
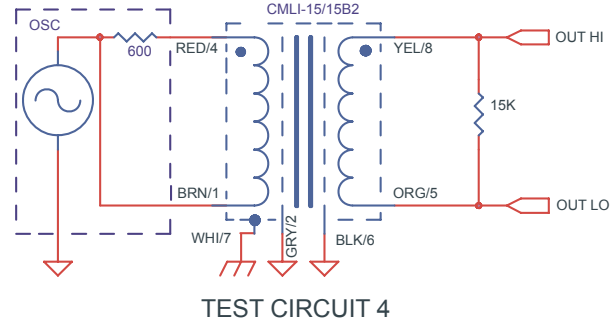
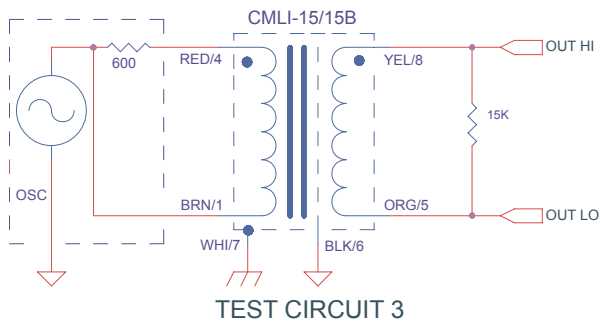
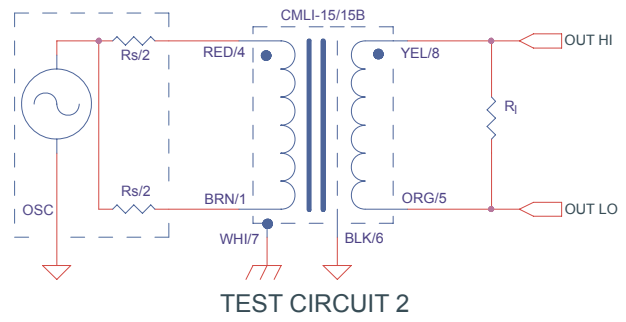
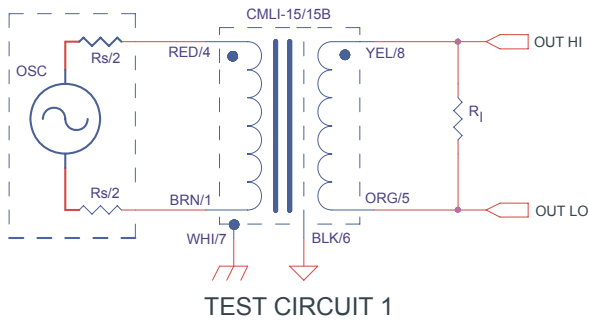

NOTES:

1. All graphs generated from one (1) randomly chosen Device. No statistical averaging or weighting. Data from one sweep.

