



Superior Magnetics Since 1979



CMMI-5C

Microphone Input Transformer

1 : 5 Step-up

- For use with medium input impedance amplifiers
- Good bandwidth (- 3 dB at 120 kHz)
- Good immunity to source impedance variances
- Good CMRR
- 13.8 dB voltage step-up; 1 : 5 turns ratio
- Low profile package

The CMMI-5C is commonly used in commercial grade applications and has a moderately high secondary impedance. It exhibits good bandwidth, common mode rejection ratio (CMRR), and good distortion characteristics. The CMMI-5C is available both in a p.c. mount package as well as with leads. This device is popular with many audio engineers for professional grade designs. It is encased in a μ Metal can which provides 30 dB of magnetic shielding. As with all CineMag transformers, the wires from the internal foil shields between windings are all spot welded for maximum long term reliability.

As with all moderate to high impedance devices, care should be exercised in the design of the amplifier it feeds to assure best performance.

CMMI-5C / CMMI-5CPC

Parameter	Conditions	Typ
Turns Ratio		1 : 5.00
Voltage Gain	1 kHz, -20 dBu 150 Ω input, 39.2K secondary load impedance	13.8 dB
Distortion (THD+N%)	1 kHz, +0.0 dBu Test Circuit 1	0.0006%
	20 Hz, -20 dBu Test Circuit 1	0.025%
Max 20 Hz input level	1.0% THD; 150 Ω input, 39.2K secondary load impedance Test Circuit 1	+10 dBu
Response, ref 1 kHz	20 Hz -20 dBu Test Circuit 1	-0.08 dB
	20 kHz -20 dBu Test Circuit 1	+0.15 dB
	-3 dB	120 kHz
Phase Shift at 20 Hz	Referenced to source generator Test Circuit 1	+2°
Phase Shift at 20 kHz		-8°
CMRR	60 Hz Test Circuit 2 per IEEE Std 389-1996 ¶19	96 dB
	1 kHz Test Circuit 2 per IEEE Std 389-1996 ¶19	72 dB
Operating Temp Range	Operation and storage	0° C Min 70° C Max
Max Soldering Temp (p.c.)	5 Seconds	335° C Max

9050 Independence Ave. Canoga Park, California 91304 ☎(818) 993-4644 ☒(818) 993-4604

<http://www.cinomag.biz>

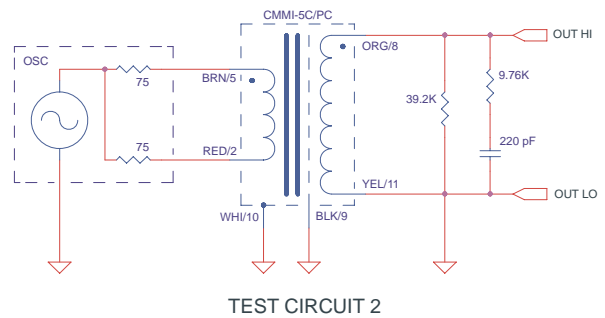
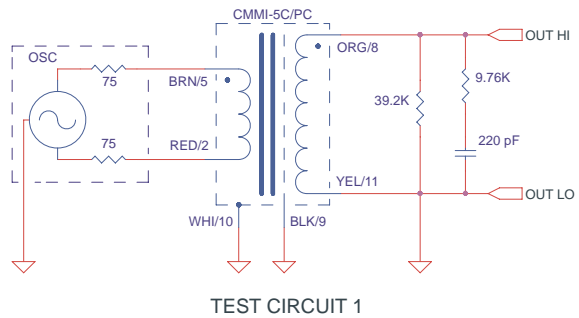
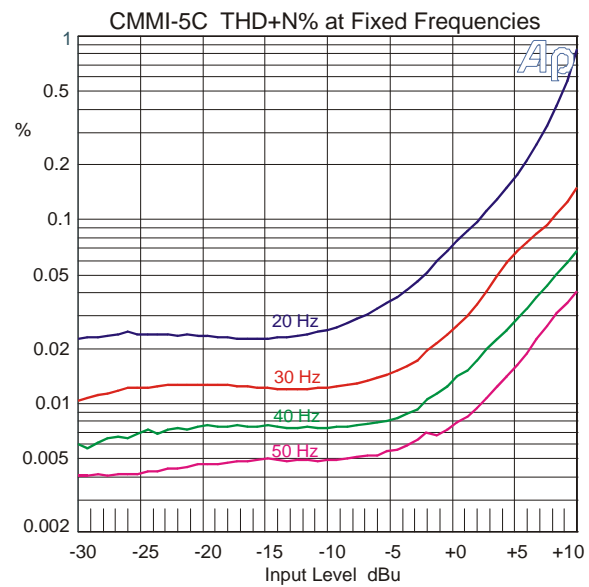
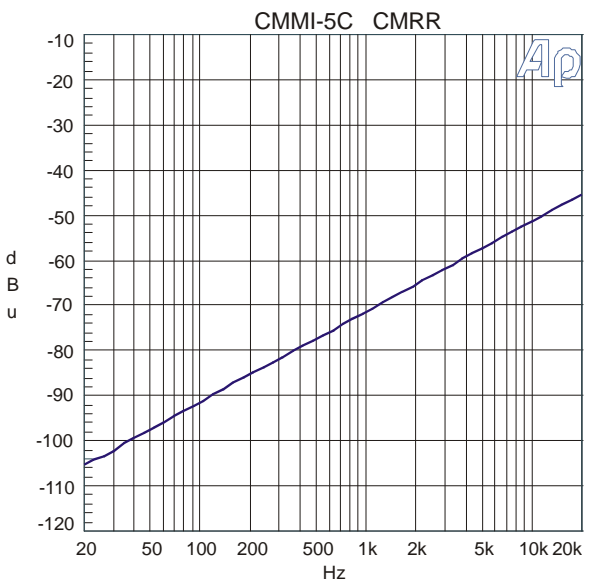
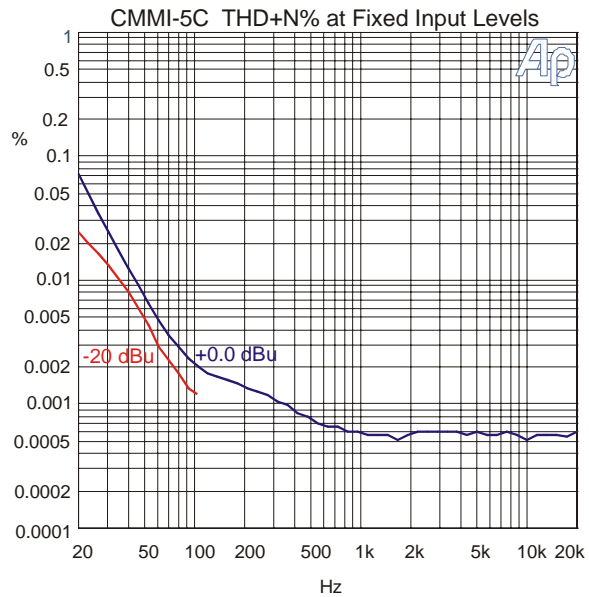
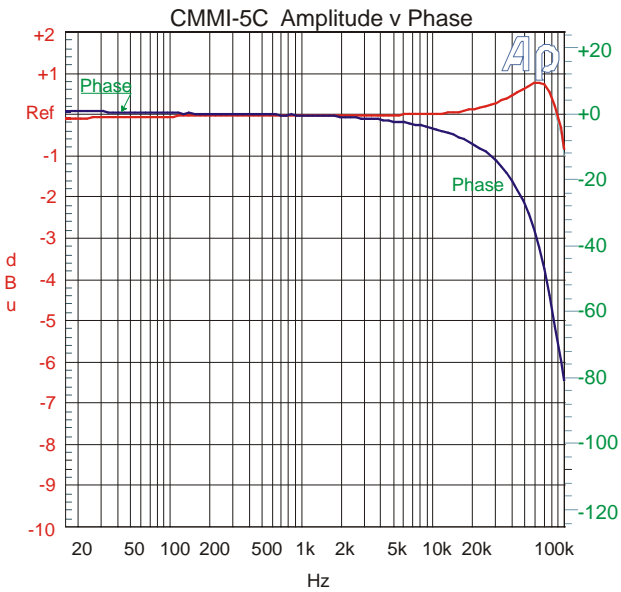

NOTES:

1. All graphs generated from one (1) randomly chosen device. No statistical averaging or weighting. One sweep taken.

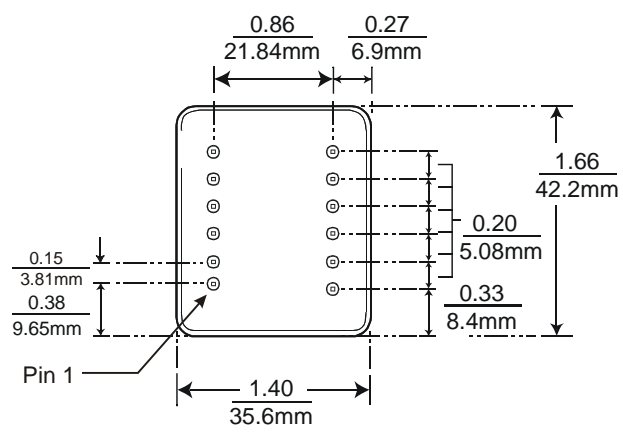
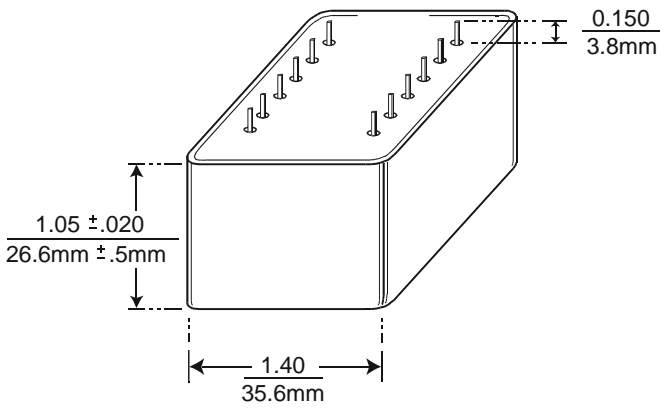
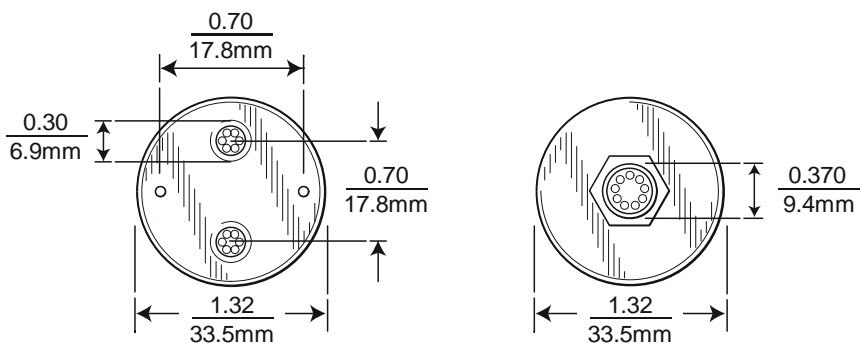
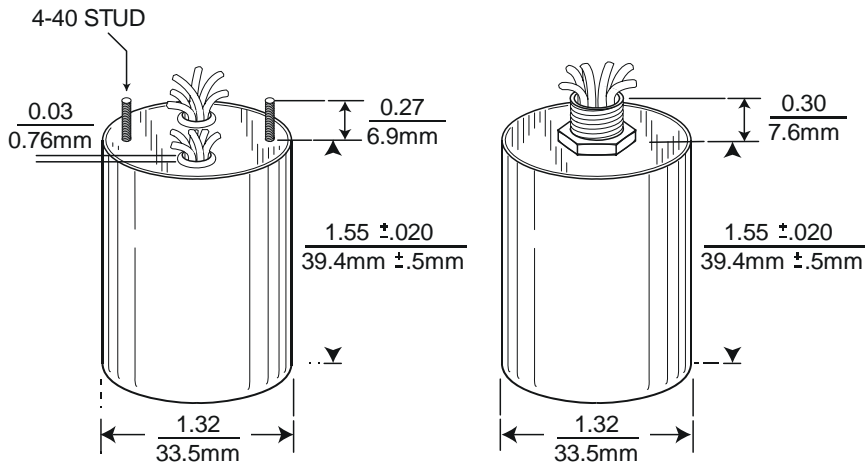

BOTTOM VIEW