



Superior Magnetics Since 1979



CMOB-3

LINE OUTPUT TRANSFORMER Bifilar Windings

- Excellent bandwidth: -0.1 dB at 200 kHz,
- $R_s=150\Omega$
- 80% Nickel ("HiNi") or 50% Ni/50% Steel laminations
- Distortion $\leq 0.02\%$ typ at 20 Hz, $R_s=150\Omega$ HiNi
- +24 dBm at 20 Hz, 1% THD+N $R_s \leq 150\Omega$
- Phase Shift -0.2° at 20 kHz, $R_s=150\Omega$
- Low insertion loss

The CineMag CMOB-3 output transformer uses bifilar construction techniques. This two winding transformer delivers good coupling between windings as well as excellent bandwidth. It is available both with 80% Nickel ("HiNi") and 50% Nickel/50% Steel laminations. It was designed to be driven from source impedances of up to 600 Ω . As with all line driving devices, the amplifier feeding it should be capable of cleanly delivering the power required to reach maximum operating level.

CMOB-3H / CMOB-3L

| Parameter | Conditions | Typ |
|--|---|---------------------------------|
| Turns Ratio | | 1 : 1.00 |
| Input Impedance, Zi | 20 Hz to 20 kHz, 0 dBu Test Circuit 3 | 637 Ω |
| Voltage Gain | 1 kHz HiNi Core, $R_s=150$ 1 kHz 50% Nickel/50% Steel Core, $R_s=150$ | -2.82 dB -2.83dB |
| Distortion (THD+N%) | 1 kHz, +4 dBu, $R_s=150$ HiNi Test Circuit 1 1 kHz, +4 dBu, $R_s=150$ 50%Ni/50% Steel | 0.0004% 0.0013% |
| Max 20 Hz input level | 1.0% THD+N, $R_s \leq 150$ HiNi Test Circuit 1 1.0% THD+N, $R_s \leq 150$ 50% Ni 50% Steel | >+24 dB +20 dB |
| Response, ref 1 kHz | 20 Hz $R_s=150\Omega$ 50%Ni50%Steel Test Circuit 1 20 kHz $R_s=150\Omega$ 50%Ni50%Steel Test Circuit 1 200 kHz $R_s=150\Omega$ Test Circuit 1 | -0.02 dB +0.01 dB -0.1 dB |
| Phase Shift at 20Hz Phase Shift at 20 kHz | Referenced to source generator Test Circuit 1 | +0.8° -0.2° |
| CMRR | 60 Hz Test Circuit 4 per IEEE Std 389-1996 ¶19 1 kHz Test Circuit 4 per IEEE Std 389-1996 ¶19 | 92 dB 98dB |
| Output CMRR | 60 Hz Test Circuit 2 1 kHz Test Circuit 2 | 112 dB 118 dB |
| Operating Temp Range | Operation and storage | 0° C Min 70° C Max |

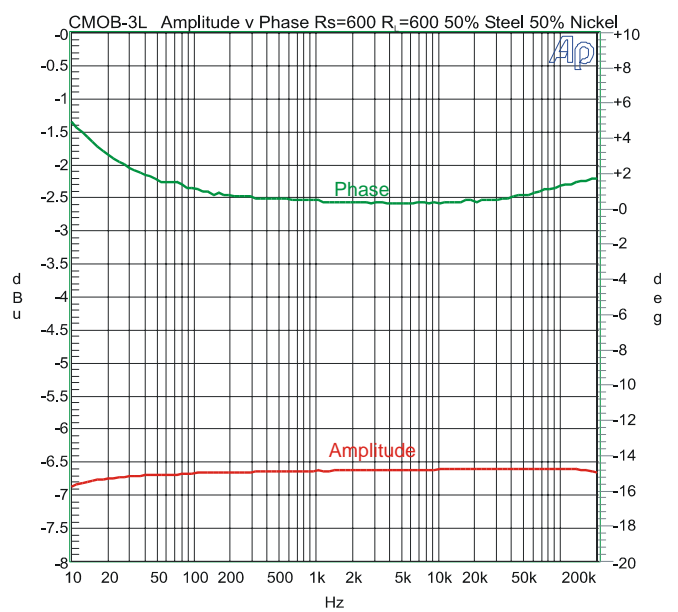
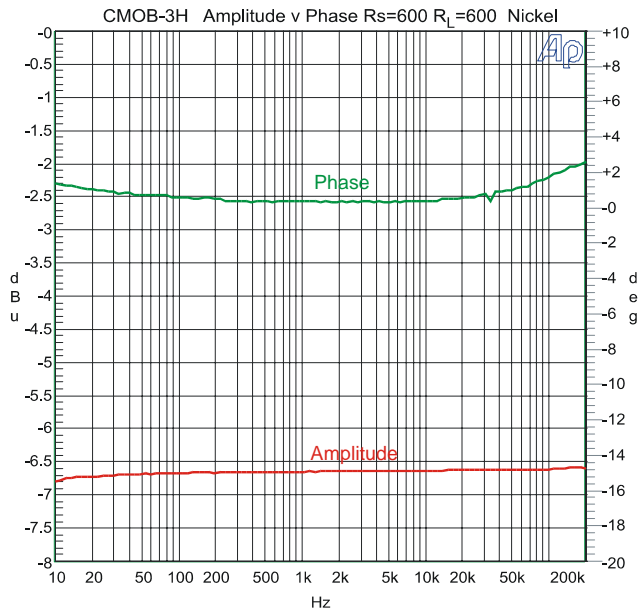
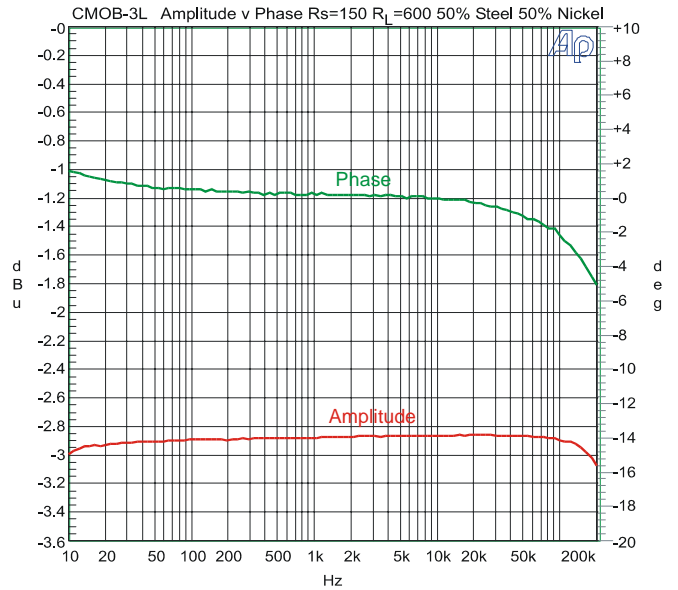
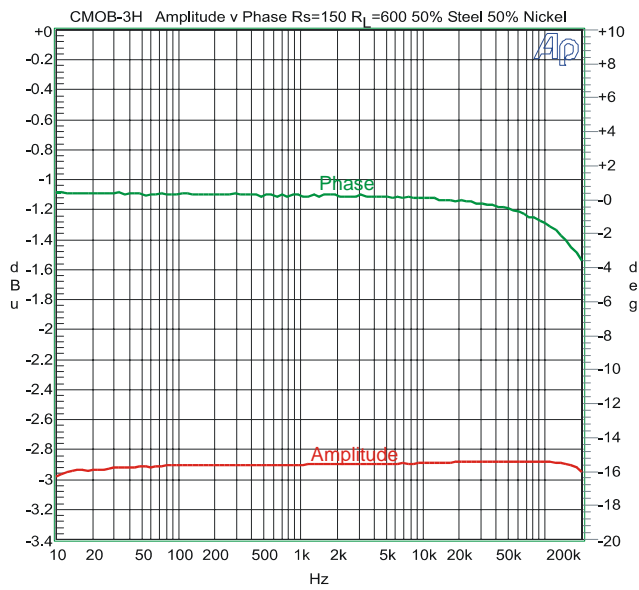
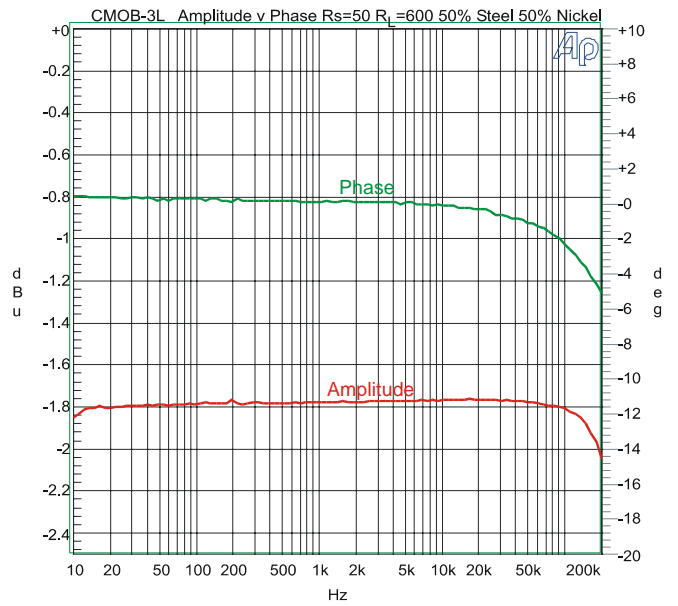
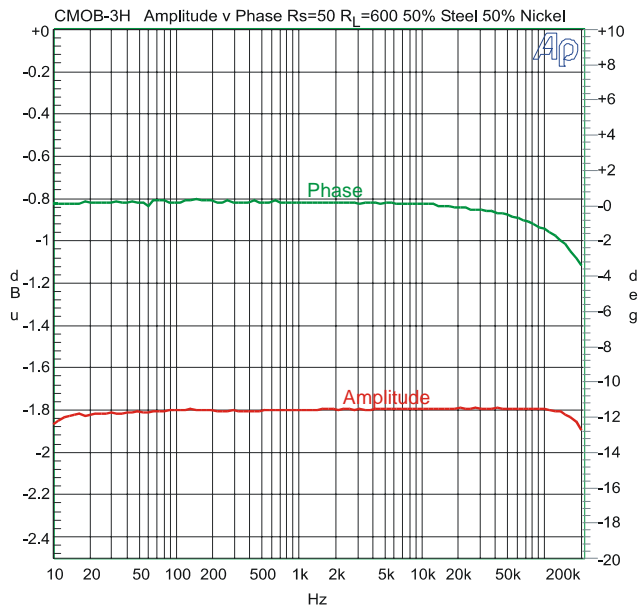

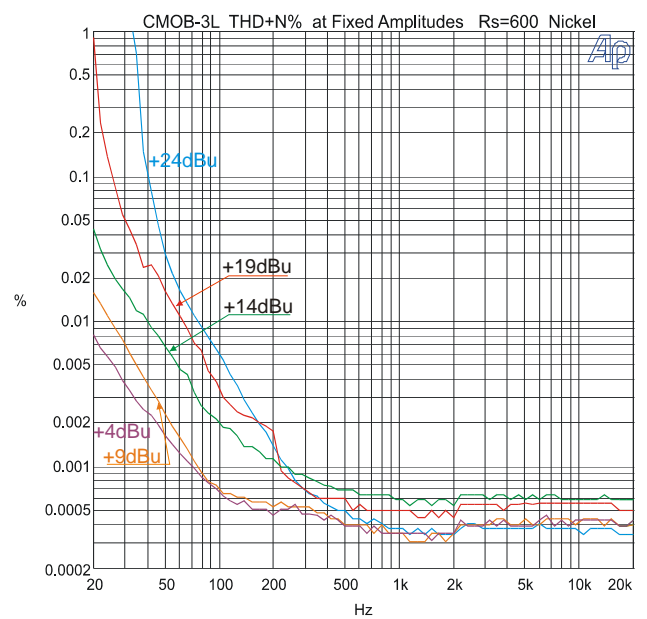
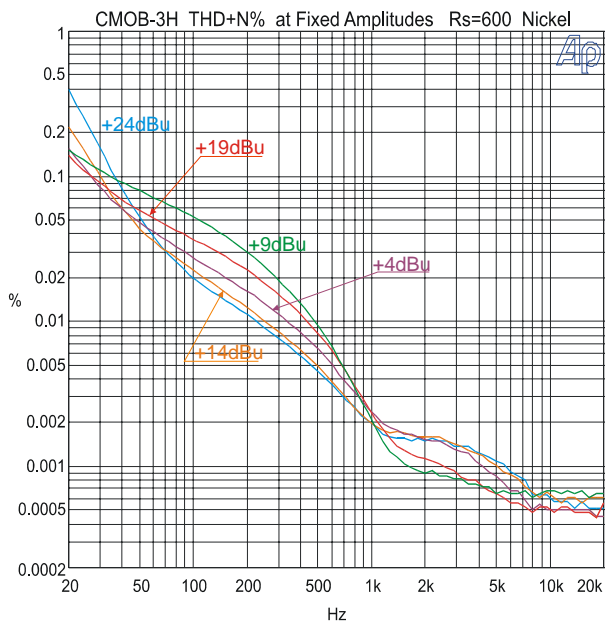
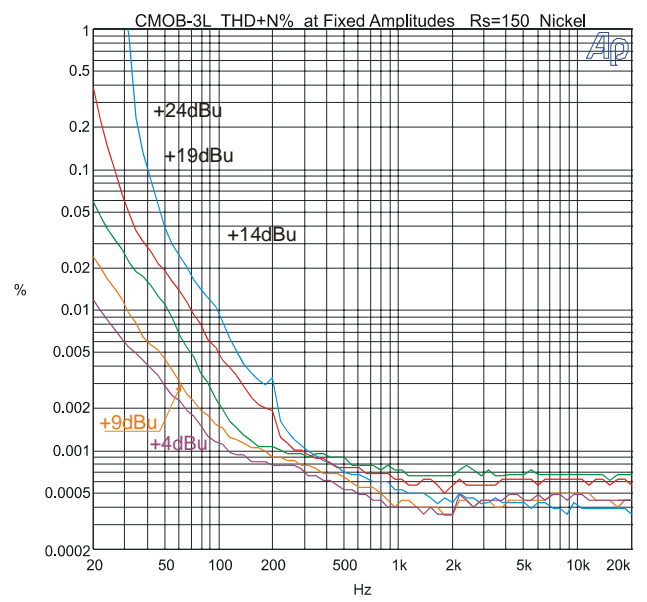
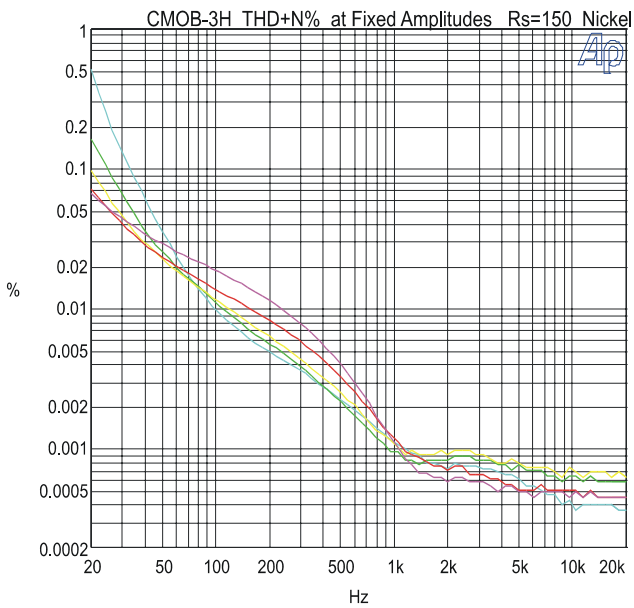
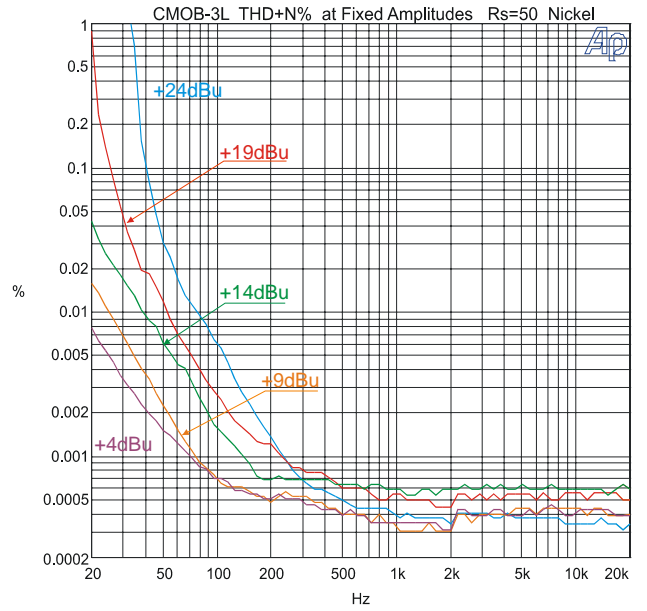
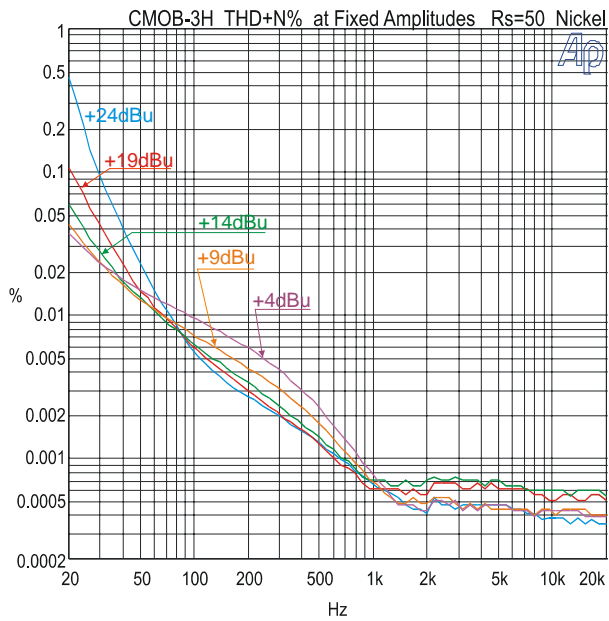

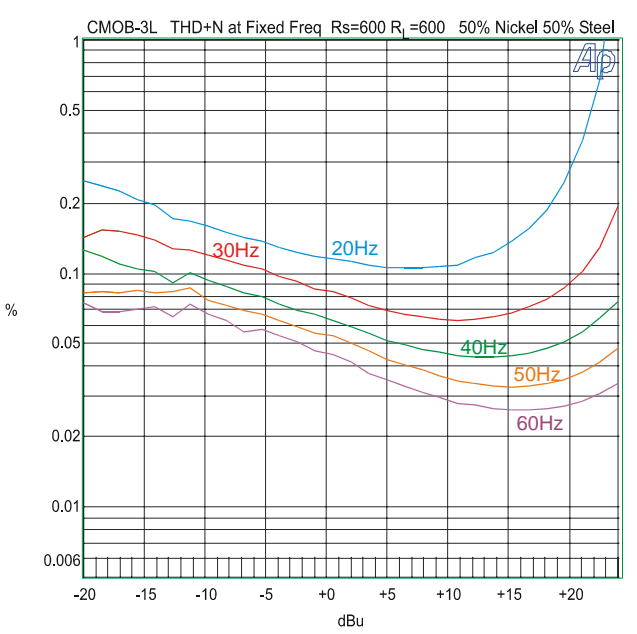
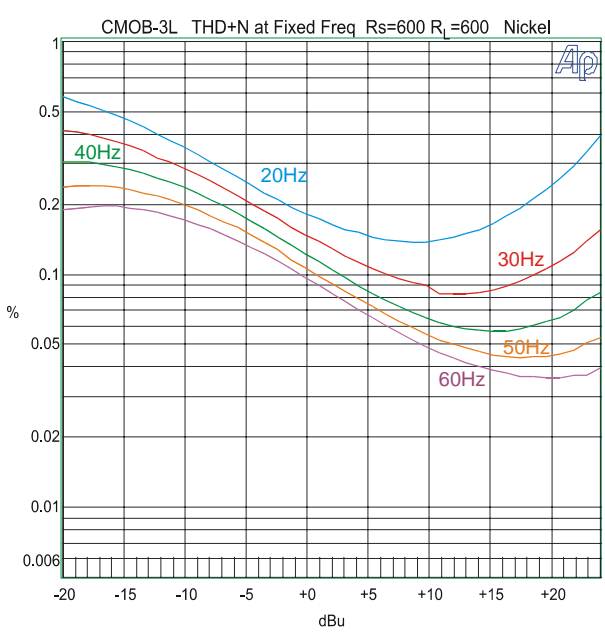
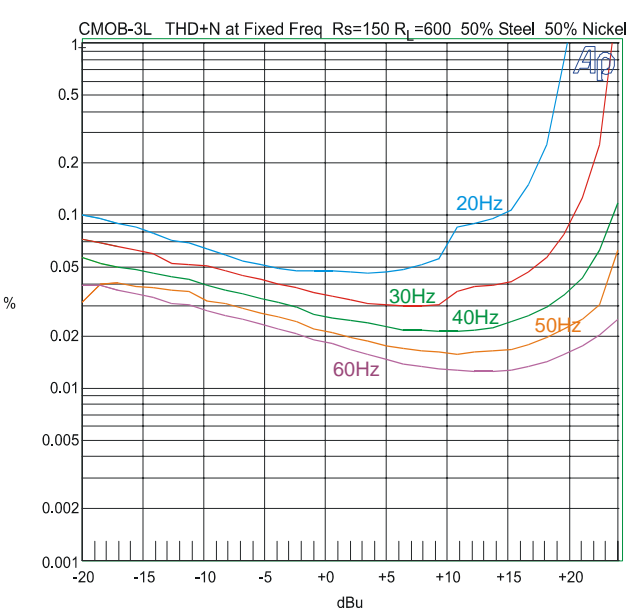
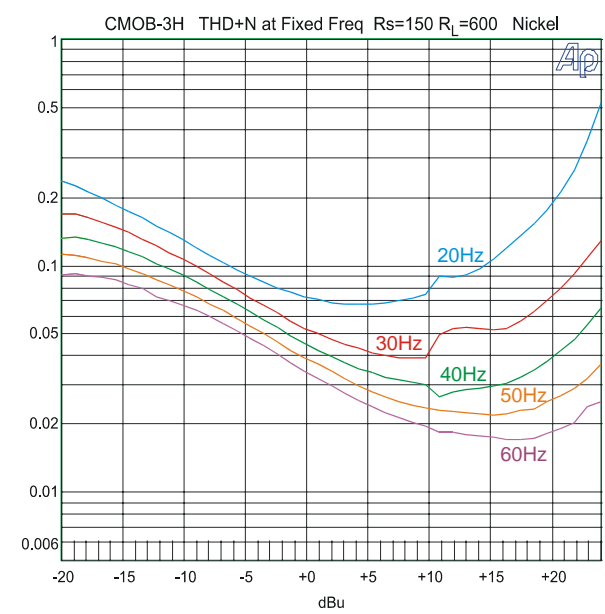
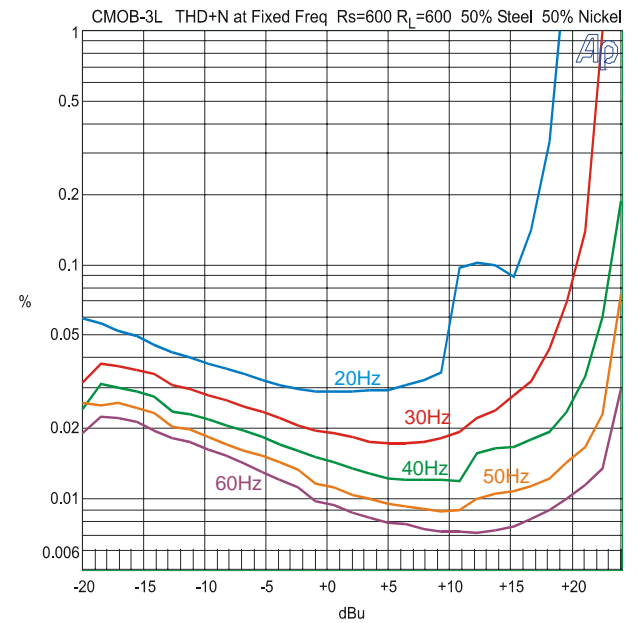
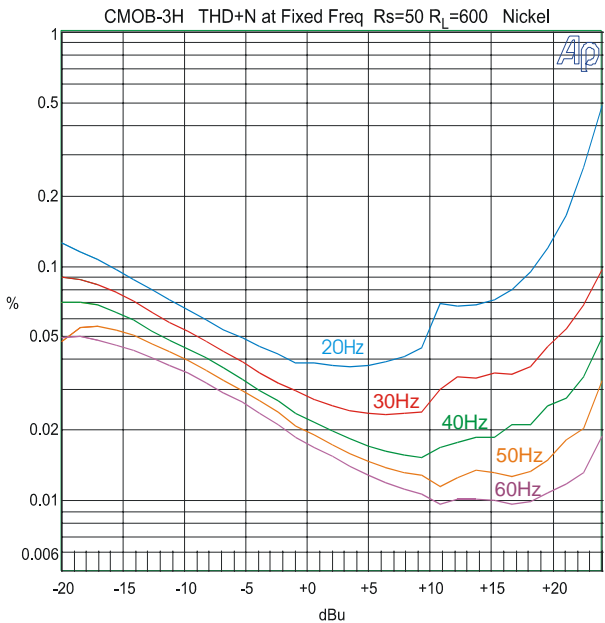

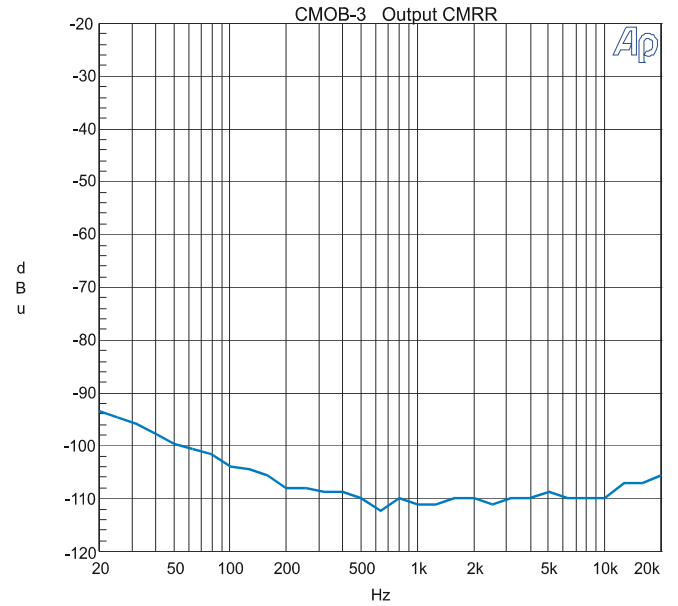
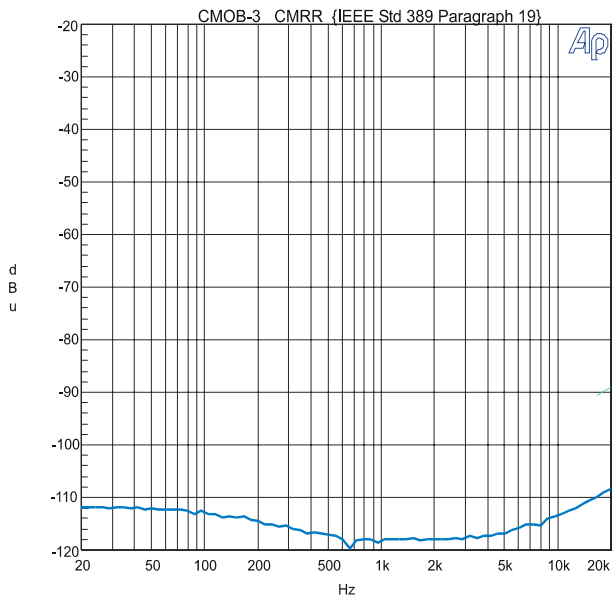

NOTES:

1. All graphs generated from one (1) randomly chosen device. No statistical averaging or weighting. Data from one sweep.
2. $R_L = 604$ unless otherwise noted.

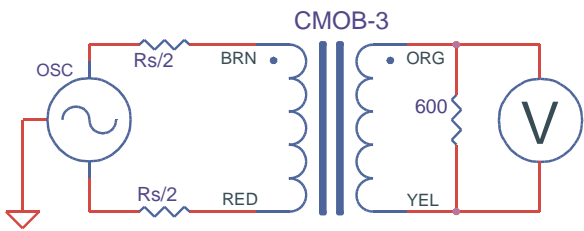

TEST CIRCUIT 1

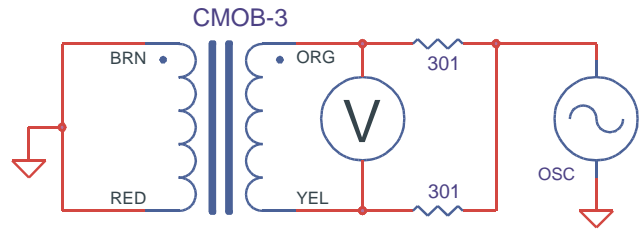

TEST CIRCUIT 2

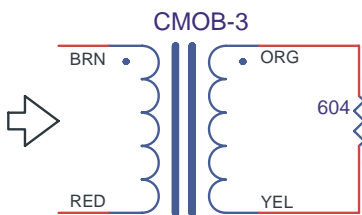

TEST CIRCUIT 3

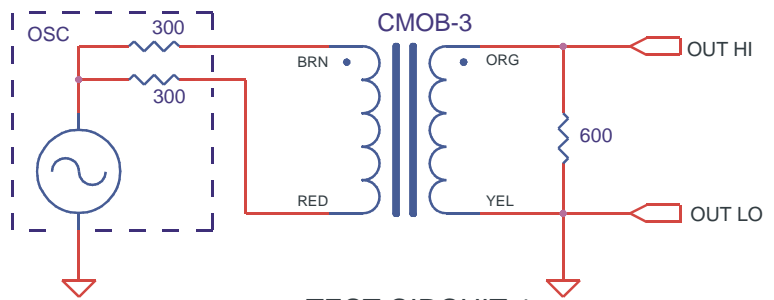

TEST CIRCUIT 4

